

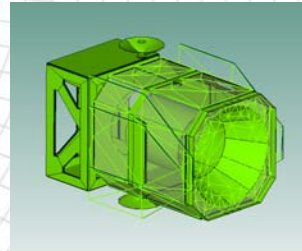

VA One

The ONE Simulation Environment for Vibro-Acoustic Analysis and Design

VIBRO - ACOUSTIC

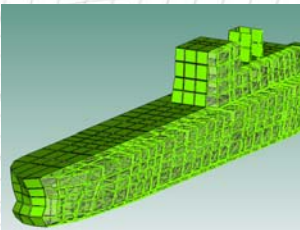
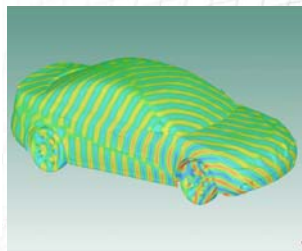
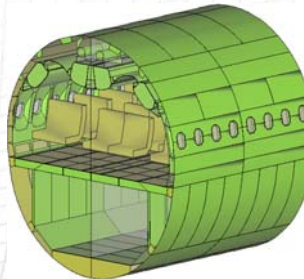
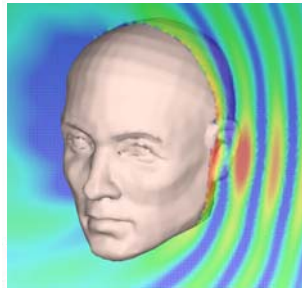
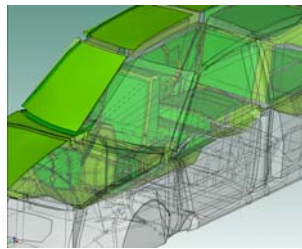



Lighter, faster and quieter ...

Government legislation, competitive pressure and tight development schedules mean you can't afford to wait until your product is built to find unexpected noise and vibration problems. With VA One you no longer have to. Account for noise and vibration right at the design stage - no more costly delays or panic driven test-based solutions. VA One has everything you need to diagnose potential noise and vibration problems up front in your development process. Manage risk by identifying possible problem areas that may need more detailed modeling or test based development, while you still have time to make an impact on the product!

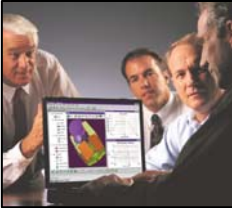

The full spectrum of solutions ...

Whether you are creating SEA models of initial concept designs or fully detailed FE models of final prototypes, VA One has all the simulation methods you need in ONE environment. Design for noise and vibration performance across the full frequency spectrum. VA One is the only simulation code on the market that offers the full-spectrum of vibro-acoustic solutions.

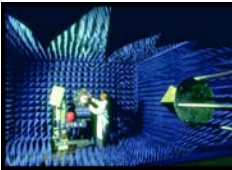

Design evaluation ...

With VA One's unique statistical modeling methods you have the flexibility to make models as detailed or as simple as you need. Create system level noise and vibration models in a matter of hours and get solutions in seconds, even on a laptop. VA One helps you rank sources and identify dominant transmission paths quickly. Get answers to key design questions in real-time, not tomorrow or next week. Find out how easy it is to introduce VA One into your product development process and start designing for noise and vibration today!



Industries and applications

Automotive/land vehicles

- Perform weight/cost optimization of interior sound package and damping treatments
- Diagnose airborne and structure-borne sound transmission through trimmed body structures and components
- Create system level models and set component level targets for suppliers
- Design for interior sound quality in automobiles, trucks, buses and land vehicles.
- Design quieter engines and powertrain components
- Predict noise radiation from exhaust lines, mufflers and intakes

Architecture

- Optimize the vibro-acoustic performance of HVAC systems, chillers, compressors, fans and motors
- Create efficient system level models of office buildings, hotels, theatres and apartments
- Predict TL and flanking paths through different building constructions
- Predict absorption and sound insulation for new partition designs and constructions
- Investigate the acoustic performance of different noise barriers

Aerospace

- Design for interior noise in commercial, executive and military aircraft
- Optimize the vibro-acoustic performance of new lightweight materials and constructions
- Reduce weight and improve fuel efficiency with the optimal design of noise control treatments
- Define random vibration, acoustics and shock environments and set acceptance and qualification levels for launch vehicles and payloads
- Analyze the response of primary structure, payload and critical flight equipment due to acoustic, random vibration and shock environments

Consumer appliance

- Diagnose transmission paths and dominant sources in consumer appliances such as dishwashers, washing machines, refrigerators and power tools
- Define requirement specifications for motors and fans in computers and electronic equipment
- Design components, casings and enclosures to minimize radiated noise
- Optimize sound quality of speakers and mobile phones

Naval/marine

- Create full system level models of shipboard noise and vibration in ships, submarines and luxury yachts
- Design for reduction of hydrodynamic and mechanical flow contributions to sonar self noise
- Minimize signatures and reduce underwater noise radiation

Rail

- Diagnose transmission paths and optimize interior sound package
- Design for interior sound quality
- Analyze wheel-rail interaction, engine and aerodynamic noise
- Model pass-by-noise and community noise impact

Process and industrial machinery

- Design noise control treatments for process equipment to eliminate operator/occupant hearing loss
- Ensure government regulations for noise levels and exposure can be met with minimum additional cost

The VA One environment

VA One is the only environment you need for vibro-acoustic simulation and design. Whether you're simulating the acoustic transmission loss of an automotive firewall or creating a system level model of the vibro-acoustic response of a complete aircraft, VA One has all the methods you need to simulate vibro-acoustics across the entire frequency spectrum. Based on the industry standard software for mid and high frequency noise and vibration design **AutoSEA2**, and extended to encompass mid and low frequency methods (making use of the **RAYON** solver), VA One is the only simulation code on the market that contains the complete spectrum of vibro-acoustic analysis methods in a common environment. VA One also sets new standards in ease of use; VA One is a standalone Windows desktop application with a modern user interface that is quick, intuitive and very easy to use. With VA One you get results faster. Spend your time solving noise and vibration problems rather than trying to learn how to use complex CAD/CAE systems or relearning the user interfaces of a large number of disparate analysis codes. With VA One you get all the functionality you need for vibro-acoustics in one common environment.

The core functionality of VA One is split into five main modules: the **SEA Module**, **Structural FE Module**, **Acoustic FE Module**, **Acoustic BEM Module** and **Hybrid Module**. Adding a new module is simple and straightforward and gives you access to the methods you need to model the response of a vibro-acoustic system in a given frequency range. In addition, a large number of extension modules and scripts are available to help you customize VA One to meet specific requirements. These extension modules provide everything from customized model templates for specific applications to complete developer kits for writing custom scripts and GUIs within the VA One environment. VA One has the flexibility to meet your analysis needs.

Find out why more and more companies are choosing ESI's software to help address their vibro-acoustic simulation requirements and how VA One can help you improve the noise and vibration performance of your products.

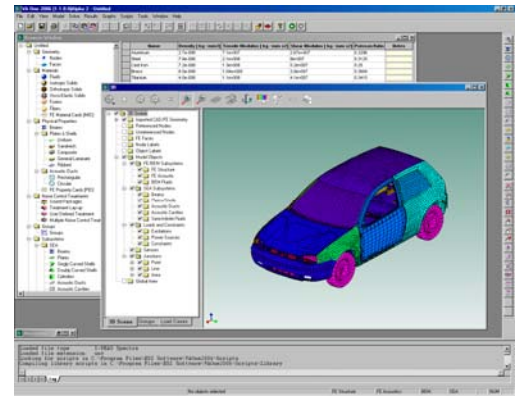

Vehicle model courtesy of Volkswagen

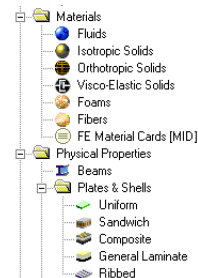

VA One uses an intuitive object oriented database of modeling objects. Quickly interact with the objects in your model using a combination of the spreadsheet like "browser windows" and graphical "3D windows"

VA One contains extensive inbuilt functionality for working with graphs and spectra. Easily access the data in a graph and copy and paste between different applications.

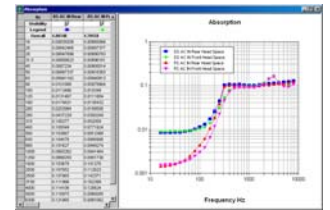

Walk through example

1. Create geometry

Import from existing CAD or FE models or create geometry directly within VA One.

2. Create subsystems

Create structural and acoustic SEA, FE and BEM subsystems and assign physical properties.

3. Create junctions

Automatically create junctions using "AutoConnect". Add isolators and proelastic noise control treatments.

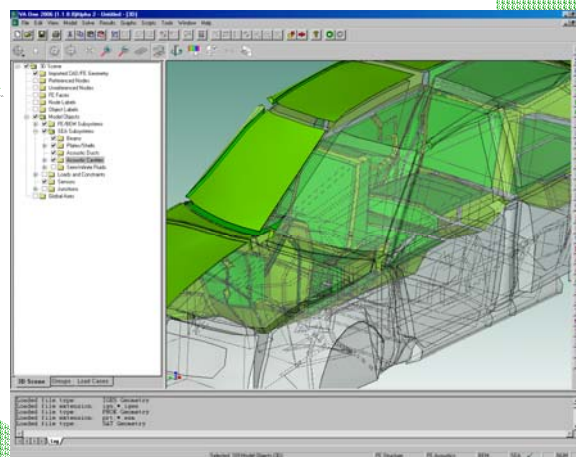

4. Add loads/constraints

Apply structural and acoustic loads directly to subsystems (including a complete library of random acoustic loads).

5. Intermediate results

Get intermediate modal results for FE/BEM subsystems using inbuilt or external solvers, or by importing pre-computed data.

8. Design

Evaluate design changes and release your product with noise and vibration quality assured.

7. Diagnose

Look at contour plots, graphs, animations and energy flows to diagnose transmission paths and evaluate response.

6. Full Solve

Solve for the fully coupled response of all FE/BEM/SEA subsystems in the model.

The most flexible VA modeling environment on the market!

VA One has a complete library of vibro-acoustic subsystems and all the junctions you need to couple them together.

High modal density plate and shell structures efficiently modeled using SEA plate, cylinder and singly curved shell subsystems

SEA semi-infinite fluid subsystem used to model acoustic radiation from SEA structural components

High modal density cavities efficiently modeled using SEA acoustic cavity subsystems

Structural source modeled by a point force applied to SEA singly curved shell subsystem

Fluid and structure-borne noise transmission through low modal density piping system accurately modeled using FE structure and FE acoustic cavity subsystems

Boundary Element fluid subsystem used to model acoustic radiation from stiff piping structure

Airborne sources can be modeled as user defined input power applied directly to SEA acoustic cavity subsystem

Cylinder endcaps modeled with SEA doubly curved shell subsystems

Junctions between subsystems created automatically using AutoConnect functionality

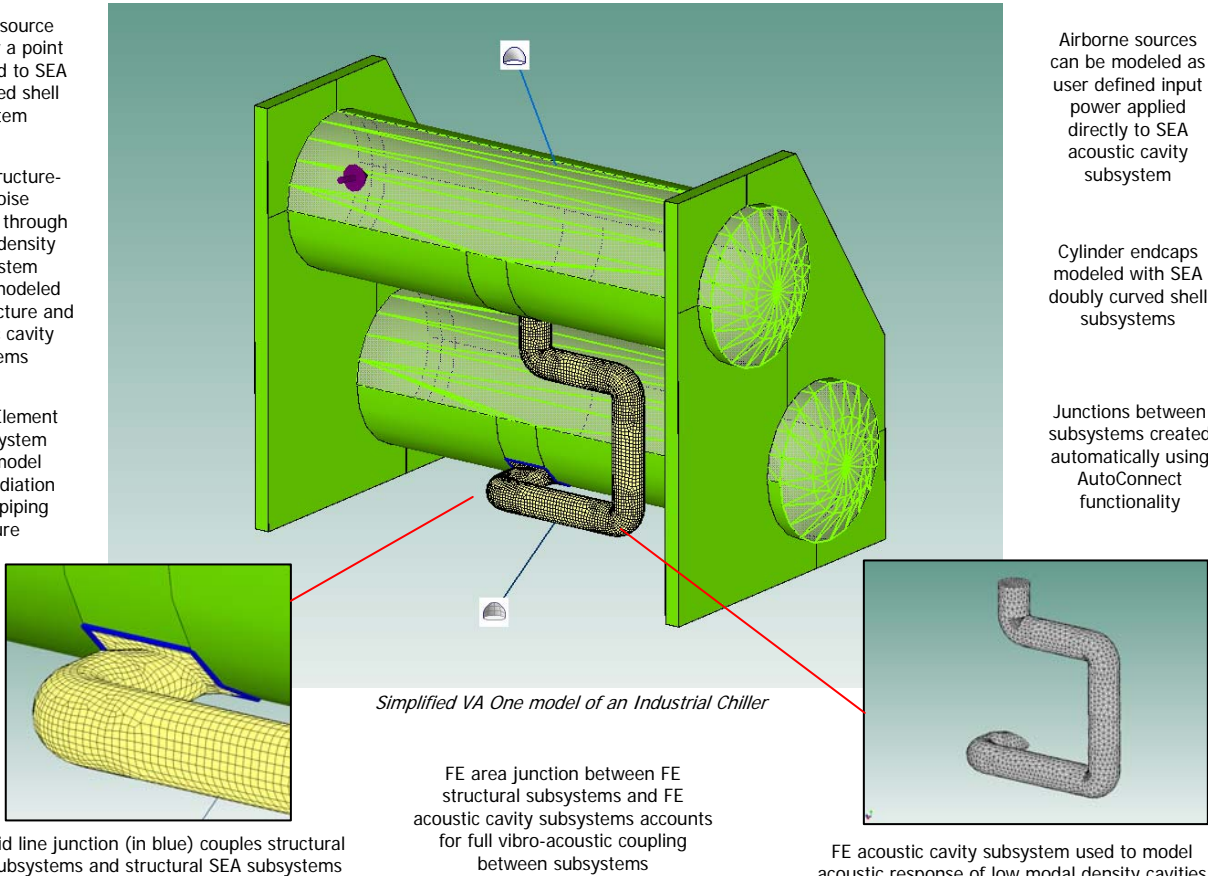

Simplified VA One model of an Industrial Chiller

Hybrid line junction (in blue) couples structural FE subsystems and structural SEA subsystems

FE area junction between FE structural subsystems and FE acoustic cavity subsystems accounts for full vibro-acoustic coupling between subsystems

FE acoustic cavity subsystem used to model acoustic response of low modal density cavities

“Boeing Integrated Defense has been a long term and successful AutoSEA2 user, and now has the capability of implementing all of the common vibro-acoustics analysis techniques, which are integrated into a single software package. The combined tools provide an efficient analysis environment when performing analysis to support Space Shuttle and International Space Station requirements. VA One is a standard software tool for Boeing Integrated Defense vibroacoustic analysis, and it is used to support a variety of other business activities”
–Ed O’Keefe, Associate Technical Fellow, BOEING INTEGRATED DEFENSE.

“One of the advantages of VA One for automotive applications is the ability to quickly start with the evaluation of simple yet useful conceptual models and progress through the evaluation of increasingly more sophisticated models as the design evolves. VA One can provide critical design assessments well before prototype vehicles are available such that proper noise control measures can be efficiently incorporated into the design; rather than inefficiently added as band-aids late in the program”
– LEAR CORPORATION

“VA One is intuitive and straightforward to use. I was able to complete a detailed, coupled Boundary Element analysis the first time that I used the code” - Jeffrey Larko, Aerospace Engineer Structural Dynamics, NASA GLENN RESEARCH CENTER

“Even with JM’s extensive testing capabilities, the next generation of acoustical solutions require sophisticated modeling techniques. ESI’s vibro-acoustics software compliments our experimental facility proving the ideal tool for a broad spectrum of projects ranging from building construction to aerospace acoustics” – JOHNS MANSVILLE

“By using ESI’s vibro-acoustic software we were able to obtain up to 15 dB reduction in the interior sound pressure levels in one of our vehicle platforms. The software is now used in production as part of our standard vehicle design process” – Kazuki Fukui, NISSAN MOTOR COMPANY

SEA Module

The Statistical Energy Analysis (SEA) module of VA One is the evolution of the industry standard software for mid and high-frequency noise and vibration design, **AutoSEA2**. The SEA module is used routinely in virtually every industry for which noise and vibration are of concern. Find out why so many companies have made ESI's software a standard part of their noise and vibration design process.

Benefits

- Create efficient system level models of noise and vibration transmission in large complex systems at mid and high frequencies
- Identify key transmission paths and rank sources early in the design process
- Investigate the effects of noise control treatments (poro-elastic treatments, isolators and localized damping layers)
- Interactive design environment (create complex models that solve in seconds on a laptop – answer noise and vibration questions interactively in “real time”; spend your time solving noise and vibration problems rather than differential equations)

Features

- Full library of materials (isotropic, orthotropic, viscoelastic, foam/fiber etc.)
- Full library of physical properties (uniform, ribbed, laminate, composite etc.)
- Complete library of SEA subsystems (beams, plates, shells, cylinders, ducts, acoustic cavities, semi-infinite fluids etc.) and structural and acoustic loads
- Account for pressurization, fluid loading, stiffening from curvature
- Automatic calculation of SEA coupling loss factors for point, line and area junctions based on full-wave transmission theory (and advanced radiation efficiency algorithms)
- Easy to use 3D modeling environment, visibility tree and object oriented database simplify model creation, model management and diagnosis of results

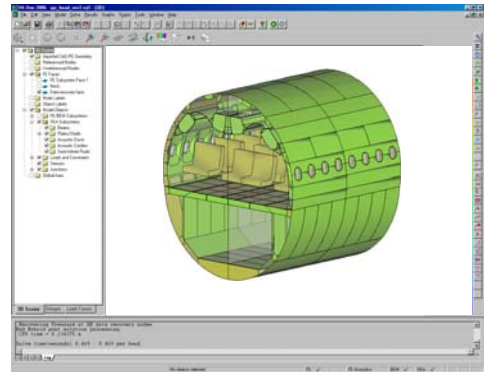

Fuselage model courtesy of Boeing Commercial Airplanes

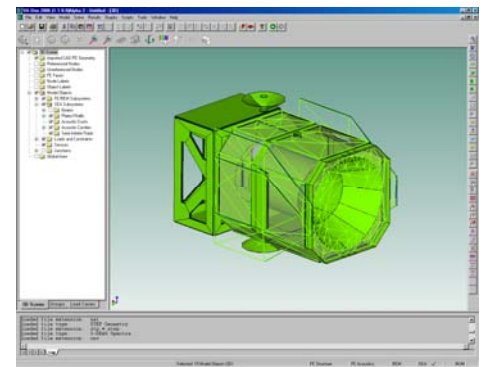

Spacecraft model courtesy of NASA

Hybrid Module

The Hybrid Module gives you the state-of-the-art in vibro-acoustic analysis methods. Developed as part of a long term research program by ESI, in conjunction with leading academic institutions and industrial consortia, this module enables you to create **fully coupled FE/BEM/SEA models** in a single analysis. The ultimate in modeling flexibility, use the right combination of subsystems to accurately model the response of your product across the entire frequency spectrum.

Benefits

- Create efficient system level models of noise and vibration across the full frequency spectrum (including the difficult mid-frequency range)
- Extend your existing SEA models to mid and low frequencies by adding local FE subsystems to describe complex junctions and stiff components
- Refine the dominant transmission paths in your models with the use of FE subsystems (optimize junction designs to minimize structure-borne transmission, optimize local constructions for minimum input power)
- Extend your existing FE/BEM models to higher frequencies (remove computational expense and capture the physics of a problem by modeling high modal density subsystems statistically with SEA)
- Quickly add SEA acoustics, poroelastic materials and random acoustic loads to existing FE models (perform TL, radiation efficiency and diffuse acoustic loading predictions in a fraction of the time it takes to perform a full FE/BEM/IEM calculation)

Features

- Hybrid point, line and area junctions between FE structure and SEA subsystems/loads (include isolators and poroelastic treatments)
- Fully coupled models and full implementation of the Hybrid FE/SEA method

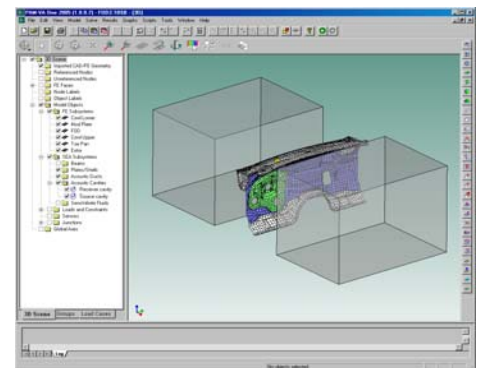

Hybrid FE-SEA dash model courtesy of General Motors

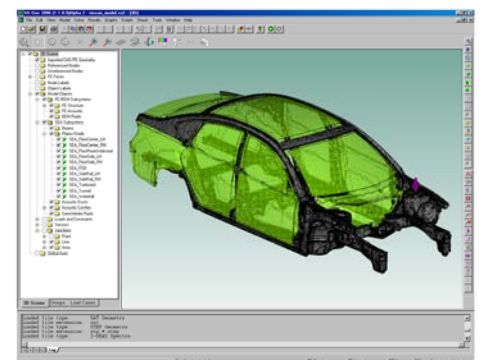

Hybrid FE-SEA structure-borne noise model

Acoustic FE Module

The Acoustic Finite Element (FE) Module gives you all the functionality you need to add fully coupled FE acoustic cavity subsystems to your VA One models. Ideally suited for creating accurate models of enclosed acoustic cavities at low frequencies and for optimizing the low frequency performance of poroelastic noise control treatments.

Benefits

- Create accurate models of the response of acoustic cavities at lower frequencies (when the response of an acoustic cavity is controlled by a small number of dominant acoustic modes)
- Quickly and easily find the optimal location and lay-up of poroelastic noise control treatments for maximum absorption at mid and low frequencies
- Create fully coupled structural acoustic models (account for full coupling between FE structural subsystems and FE acoustic cavities)

Features

- Inbuilt volume mesher (easily convert between SEA and FE cavities)
- Automatic creation of FE area junctions between FE structural subsystems and FE acoustic cavity subsystems using AutoConnect functionality (full support for non-compatible meshes and modal projection)
- Inbuilt Acoustic FE solver for calculating acoustic modes and natural frequencies of FE acoustic cavities
- Easily apply velocity constraints to surface regions of FE cavity subsystems
- Create efficient models of layered poroelastic noise control treatments applied to surface regions of an FE acoustic cavity (uses advanced computationally efficient algorithms based on the full Biot equations)
- Fully coupled solution (FE acoustic cavity subsystems are fully integrated within the VA One environment and solution)

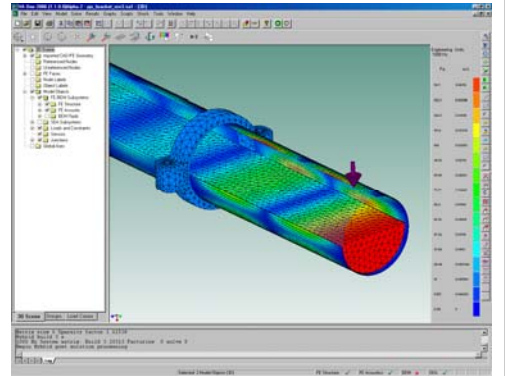

Coupled structural-acoustic response of a water filled pipe

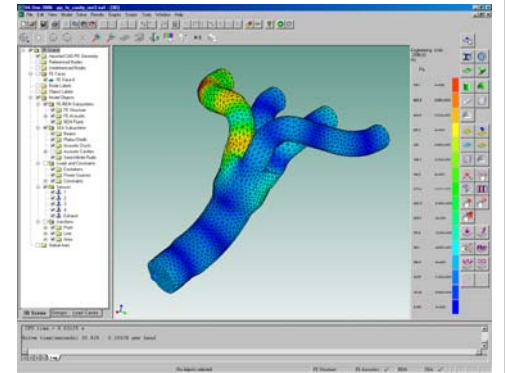

Forced acoustic response of an exhaust manifold

Acoustic BEM Module

The Acoustic Boundary Element Module contains all the functionality you need to model the low frequency response of bounded and unbounded fluids within the VA One environment. The module is the evolution of the **RAYON** Boundary Element solver and enables you to create accurate models of fluid loading, scattering, radiation and transmission of sound at low frequencies.

Benefits

- Create detailed "component level" models of acoustic radiation and scattering at low frequencies (and/or for small, stiff components)
- Quickly add BEM fluids to existing FE models to account for random acoustic loads, heavy fluid loading and acoustic radiation
- Investigate acoustic diffraction, propagation, scattering and shadowing
- Investigate the detailed near field response and directivity pattern associated with acoustic radiation from complex baffled and unbaffled components
- Use information from a component level BEM model to update a system level SEA model (update radiation efficiencies, input powers etc.)

Features

- Advanced Fast Multipole Boundary Elements for large models
- Indirect and Direct Boundary Element methods
- Inbuilt mesh coarsening and "shrink wrapping" algorithms
- Automatic creation of fluid and data recovery meshes
- Full support for non-compatible structural and fluid meshes
- Full structural-acoustic coupling and random vibration analysis
- Full library of acoustic loads: monopoles, plane waves, diffuse fields etc.
- Infinite planes, rigid planes, pressure release planes, baffles
- Fully coupled solution (BEM fluids fully integrated within VA One)

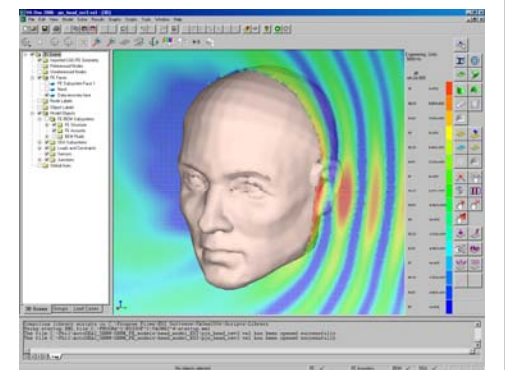

Scattering of an acoustic plane wave at 5kHz

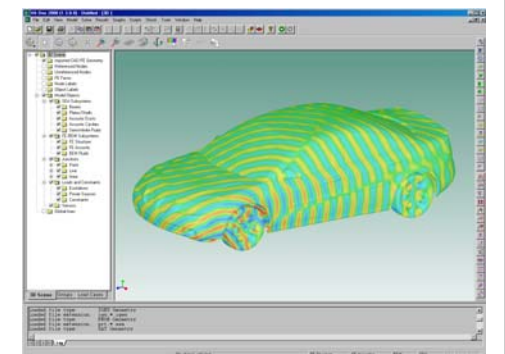

Fast Multipole BEM model of exterior pressure at 1.5 kHz

Structural FE Module

The Structural Finite Element (FE) Module of VA One contains all the functionality you need to create and work with Finite Element structural subsystems within the VA One environment. Create and solve for the response of structural FE subsystems entirely within VA One using the inbuilt Nastran solver and/or import existing models and results from a large variety of external FE solvers.

Benefits

- Create accurate models of the response of structural components at low frequencies (when the response of a subsystem is controlled by a small number of dominant structural modes)
- Quickly and easily perform modal and random vibration analyses entirely within the VA One environment
- Use VA One as a fully-functional vibro-acoustics pre and post-processor for your existing Nastran solver or use the inbuilt Nastran solver
- Quickly perform a modal contribution analysis and gain insights into the parameters controlling the response at low frequencies
- Assign different damping loss factors to different FE subsystems (accurately account for non-uniform damping distributions)

Features

- Import FE geometry and modal data in a variety of file formats including: Nastran, IDEAS, ANSYS, ABAQUS, FLUENT, Hypermesh and many others.
- Import/export of full FE models in Nastran format (support for beams, shells, solids etc.). Edit and assign material and physical properties directly within VA One
- Inbuilt meshing and remeshing functionality (create structural FE subsystems directly within VA One; easily convert SEA subsystems to FE subsystems and vice-versa; import and mesh CAD data within VA One)

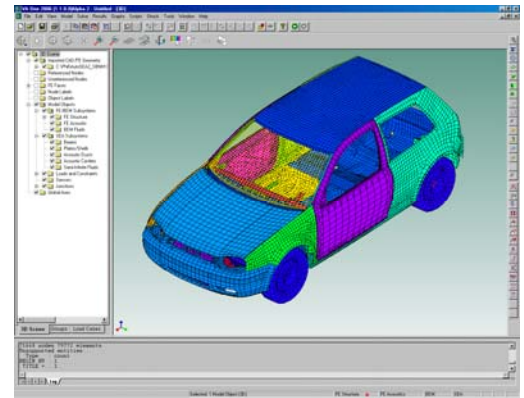

Vehicle model courtesy of Volkswagen

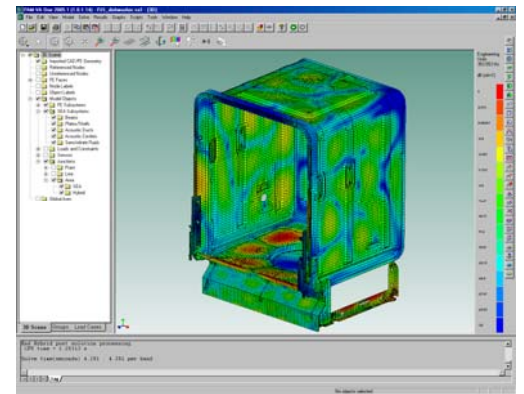

Random vibration analysis of a Dishwasher

Extension Modules

Quickly and easily extend and customize the core-functionality of VA One to suit specific needs. The extension modules for VA One are individually licensed and enable you to tailor the functionality in VA One for specialized applications.

VA One Environment Extension Modules:

- **Quickscript Module** : inbuilt basic scripting language for VA One
- **Matlab(R) Developer Kit** : interface VA One and Matlab
- **C/C++ Developer Kit** : interface VA One and C/C++ programs
- **CAD Import Modules** : import CAD data from CATIA, PRO-E and STEP
- **Foam Module** : create advanced models of multilayer poroelastic noise control treatments using full Biot theory

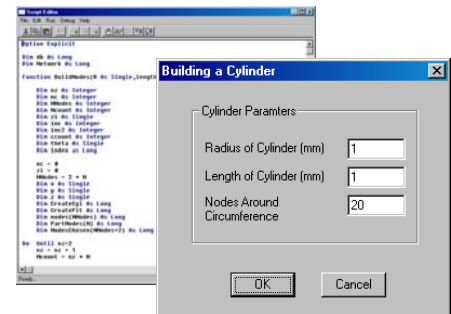

Create customized scripts and GUIs within VA One using the Quickscript module

SEA Extension Modules:

- **Sound Package Module** : simplifies addition/removal of sound packages applied to SEA subsystems
- **Variance Module** : predict confidence intervals and percentile limits for SEA results
- **Shock Module** : predict shock response from an SEA model using the method of Virtual Mode Synthesis
- **Path 49 Module** : replicates the radiation efficiency formulations found in legacy VAPEPs models
- **Template Modeler Module** : a library of scripts for quickly creating and morphing template models
- **SEA Automotive Template Models** : a set of templates for modeling airborne noise in various vehicles (SUV, Pickup truck, Four-Door Sedan, Minivan)

Structural FE Extension Modules:

- **Periodic Subsystem Module** : create SEA models of complex subsystems using FE periodic structure theory
- **EFM Module** : exact postprocessing of a structural FE model to calculate effective CLFs and input powers
- **VSEA Module** : FRF based postprocessing of a structural FE model to calculate effective CLFs and input powers

ESI Group around the world

ESI GROUP HEADQUARTERS

ESI Group
8 RUE CHRISTOPHE COLOMB
75008 PARIS

FRANCE
Phone: +33 (0)1 53 65 14 14
Fax: +33 (0)1 53 65 14 12

ESI GROUP MARKETING

ESI Group
PARC D'AFFAIRES SILIC
99 RUE DES SOLETS
BP 80112
94513 RUNGIS CEDEX
FRANCE

Phone: +33 (0)1 41 73 58 00
Fax: +33 (0)1 46 87 72 02

EUROPE

FRANCE

ESI FRANCE
Sales & Technical Headquarters
PARC D'AFFAIRES SILIC
99 RUE DES SOLETS
BP 80112
94513 RUNGIS CEDEX
France
Phone: +33 (0)1 49 78 28 00
Fax: +33 (0)1 46 87 72 02

ESI FRANCE
LE RÉCAMIER
70 RUE ROBERT
69458 LYON CEDEX 06
FRANCE
Phone: +33 (0)4 78 14 12 00
Fax: +33 (0)4 78 14 12 01

GERMANY

ESI GmbH
Sales & Technical Headquarters
Mergenthalerallee 15-21
D-65760 Eschborn
Germany
Phone: +49(0)6196 9583-0
Fax: +49(0)6196 9583-111

ESI GmbH
Niederlassung München
Augustin-Rösch-Str. 23
80935 München
Germany
Phone: +49 89 43 650017
Fax: +49 89 43 650019

BENELUX & SCANDINAVIA

ESI BV
Gebouw Kortland
Nieuwe Tiendweg 11
2922 EN Krimpen aan den IJssel
The Netherlands
Phone: +31 180 514860
Fax: +31 180 518533

CZECH REPUBLIC & EASTERN EUROPEAN COUNTRIES

MECAS ESI s.r.o.
Brojova 2113/16
326 00 Pilsen
Czech Republic
Phone: +420 377 432 931
Fax: +420 377 432 930

SPAIN

The Virtual Try-Out Space S.L.
Edificio IKEA, Oficina 311
C/ Estartetxe, 5
48940 Leioa (Bizkaia)
Spain
Phone: +34 94 480 47 60
Fax: +34 94 480 51 99

UNITED KINGDOM

ESI-UK Limited
John Eccles House
Robert Robinson Avenue
The Oxford Science Park
Oxford, OX4 4GP
United Kingdom
Phone: +44 (0) 1865 338007
Fax: +44 (0) 1865 338100

SWITZERLAND

Calcom ESI SA
PSE-A
CH-1015 Lausanne
Switzerland
Phone: +41 21 693 2918
Fax: +41 21 693 4740

AMERICAS

USA

ESI North America
Corporate Headquarters
12555 High Bluff Drive
Suite 250
San Diego, CA 92130
USA
Phone: +1 (858) 350 0057
Fax: +1 (858) 350 8328

ESI North America
Commercial Headquarters
36800 Woodward Avenue
Suite 200
Bloomfield Hills, MI 48304
USA
Phone: +1 (248) 203 0642
Fax: +1 (248) 203 0696

ESI US R&D
6767 Old Madison Pike
Suite 600
Huntsville, AL 35806
USA
Phone: (256) 713-4700
Fax: (256) 713-4799

SOUTH AMERICA

ESI Group South America
Technical Support Office
Rua Artur de Azevedo,
1857 cj.45
São Paulo - SP 05404-015
Brazil
Phone/Fax: +55 11 3062-3698

ASIA

JAPAN

Nihon ESI K.K.
Headquarters & Sales Division
Yoyogi-Uehara West Bldg,
45-18 Oyama-cho - Shibuya-ku
Tokyo 151-0065 - Japan
Phone: +81 3 6407 2347
Fax: +81 3 6407 2395

Nihon ESI K.K.
Kansai Branch Office
Advance Esaka 5F,
8-10 Toyotsu-cho - Suita-shi,
Osaka 564-0051
Japan
Phone: +81 6 6330 2720
Fax: +81 6 6330 2740

Nihon ESI K.K.
Technical Office
Yoyogi-Uehara West Bldg,
45-18 Oyama-cho - Shibuya-ku
Tokyo 151-0065 - Japan
Phone: +81 3 3466 6866
Fax: +81 3 3466 6863

KOREA

Hankook ESI
157-033, 5F KOMEGA bldg., 660-6
Deungchon-3Dong, Gangseo-ku
Seoul
South Korea
Phone: +82 2 3664 0073
Fax: +82 2 3662 0084

SOUTH-EAST ASIA

ESI Group South-East Asia
Technical Office
96-1, Jalan PJU 1/3B
SunwayMas Commercial Center
47301 Petaling Jaya, Selangor
Malaysia
Phone: +60 (3) 78049973
Fax: +60 (12) 2739978

CHINA

ZHONG GUO ESI CO., LTD
Unit 608A, Guangdong Soft-Park
No. 11 Caipin Road, Complex bldg
Guangzhou Science City (GSC)
Guangzhou city 510663
China
Phone: +86 (020) 3206 8272
Fax: +86 (020) 3206 8107

INDIA

Sales & Technical Branch Office
Indrakrupa #17, 100 feet ring road
3rd phase, 6th block,
Banashankari 3rd stage
Bangalore 560 085
India
Phone: +91 98809 26926
Fax: +91 80401 74705

About ESI Group

ESI Group is a pioneer and world leading provider of digital simulation software for prototyping and manufacturing processes that take into account the physics of materials.

ESI Group has developed an entire suite of coherent, industry-oriented applications to realistically simulate a product's behavior during testing, to fine tune the manufacturing processes in synergy with the desired product performance, and to evaluate the environment's impact on product usage.

ESI Group's product portfolio, which has been industrially validated and combined in multi-trade value chains, represents a unique collaborative, virtual engineering solution, known as the Virtual Try-Out Space (VTOS), enabling a continuous improvement on the virtual prototype. By drastically reducing costs and development lead times, VTOS solutions offer major competitive advantages by progressively eliminating the need for physical prototypes.

